

TDS1002L 16:10 PCAP

Light bar Touch Monitor



Features

- + Flat appearance design
- + Metal shell, ultra-thin shape
- + Commercial grade LCD, LED backlight
- + Resolution 1280X800@60Hz
- + 400nits brightness, full viewing angle, excellent display
- + 10 point projection capacitive touchscreen
- + COB light bar with soft and even lighting
- + Various marquee modes, Colors and speed can be adjusted
- + Remote control switching mode, brightness and speed
- + Optional serial port controls light bar operation
- + Video interface: HDMI+VGA
- + Back VESA wall mounting hole
- + Interface structure customizable
- + Supports Windows/Android/Linux
- + 2-year warranty



Optional

- No Touch
- Video interface: Display Port
- 500-1000nits
- All-in-one(Built in motherboard)



TDS1002L Light bar Touch Monitor Specification

Model	1002L
Color	Black
Diagonal	10.1”
Aspect Ratio	16:10
Active Area	216.96X135.6(mm)
Dimensions	253X172X42.2(mm)
Resolution	1280X800@60Hz
Viewing Angle	Horizontal: 85° /85° Vertical: 85°/85°
Number of Colors	16.7M
Brightness	LCD panel: 400cd/m2,PCAP Touch: 345cd/m2
Contrast Ratio	900:1
Response Time	30ms
Touch technology	PCAP (Projected Capacitive) -10 touch
Surface hardness	6H(Mohs)
Touch precision	>2mm
Touch interface	USB 2.0
Light bar	<p>Control mode: #1: Remote(Monochromatic, seven-color gradient, marquee) #2: RS232 (Provides serial port protocol for configuring control panel. It can be set Number of lights in the light strip, configuration mode of the light strip, configuration mode The color, brightness, speed, etc.,,)</p> <p>Electrical Parameters: Lighting angle: 180° Working voltage: 12V Service life of Light:50,000hours</p>
Video interface	HDMI+VGA
Speaker	TwoX2W internal speakers
Input voltage	AC:100-240 VAC, 50/60 Hz
Power Supply	12V3A
Weight(Unpackage)	1.5KG
Shipping Dimensions	350X140X20(mm)
Temperature	Operating: 0 °C to 40°C; Storage: -20°C to 60°C
Humidity	Operating: 20% to 70%; Storage: 10% to 80%
Sealability	Touchscreen sealed to bezel
MTBF	30,000 hours
VESA Mounting	75 X 75(mm)
Warranty	2-Year
Agency Approvals	FCC, CE, ROHS
Support OS	Windows/Linux\Android
What’s in the Box	1*USB cable, 1*HDMI cable, 1*DC cable, 1*Remote control

TDS1002L-PCAP

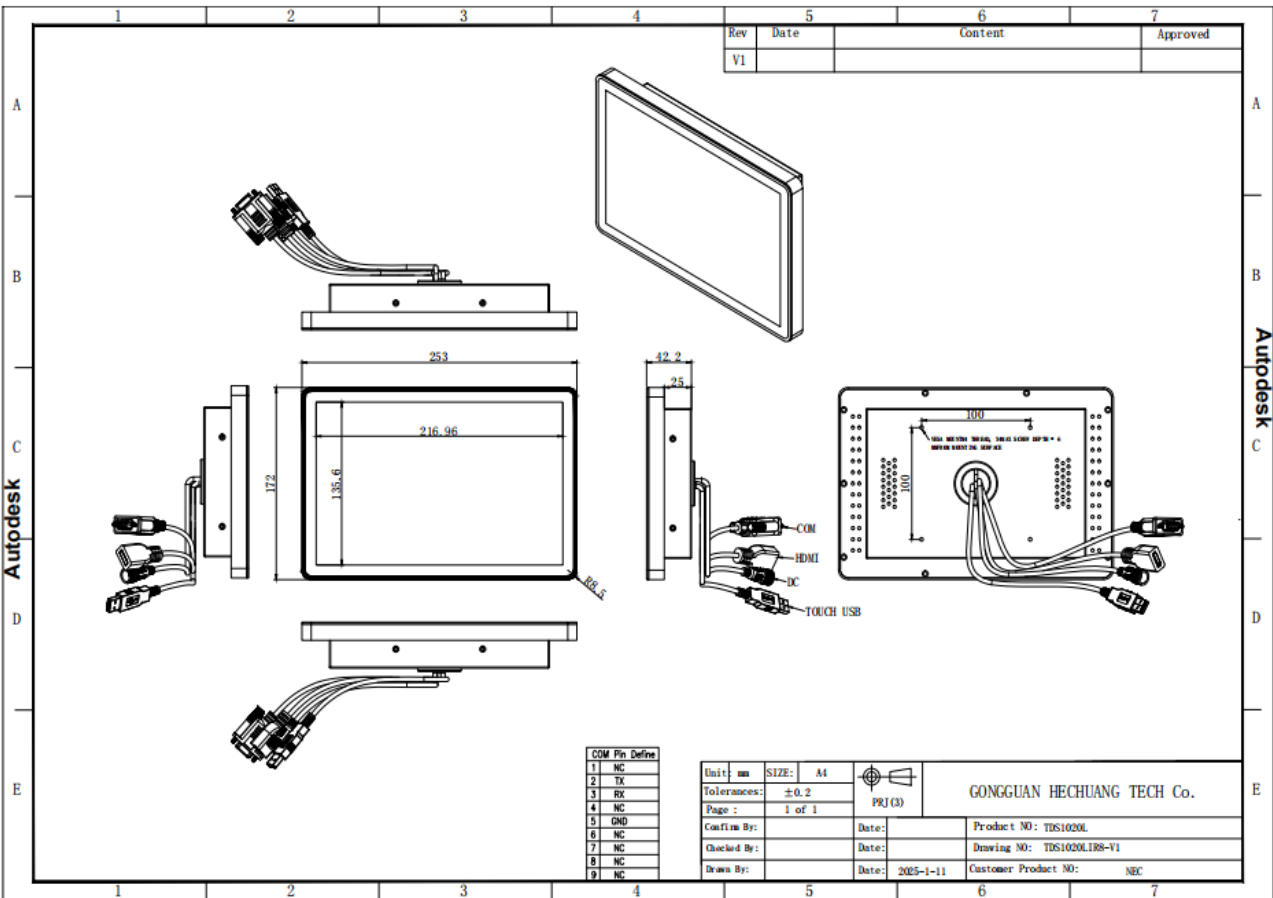

Rev	Date	Content	Approved
V1			

COM Pin Define	
1	NC
2	TX
3	RX
4	NC
5	GND
6	NC
7	NC
8	NC
9	NC

Unit:	mm	SIZE:	A4
Tolerances:	±0.2		
Page:	1 of 1		
Confirm By:		Date:	
Checked By:		Date:	
Drawn By:		Date:	2025-1-11

PRJ (3)	GONGGUAN HECHUANG TECH Co.	
	Product NO:	TDS1020L
	Drawing NO:	TDS1020L198-V1
	Customer Product NO:	NEC

Dimensions are in millimeters

