

2102D 16:9 PCAP

Digital signage Touch Monitor

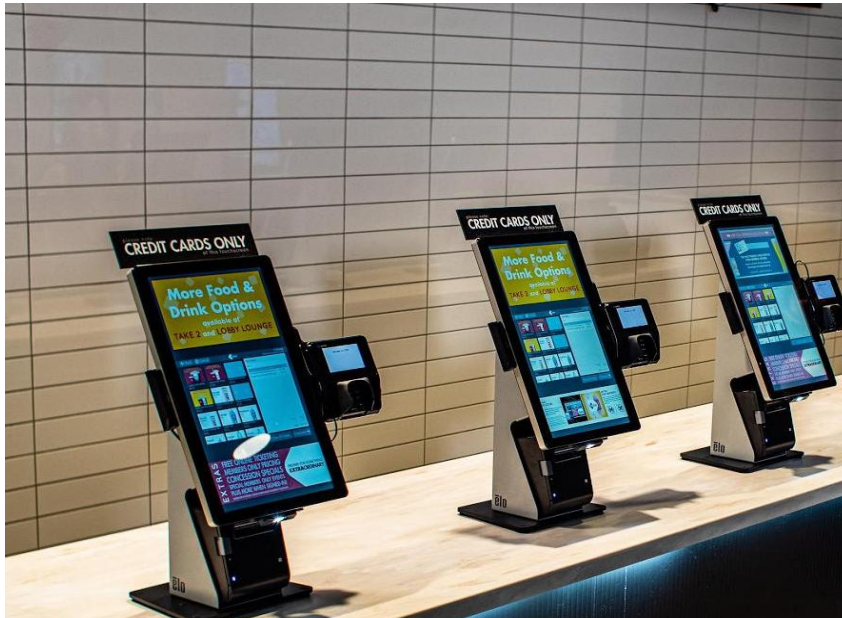

Features

- + Flat appearance design
- + Metal shell, ultra-thin shape
- + Commercial LCD, LED backlight
- + Resolution 1920X1080FHD@60Hz
- + Widescreen full viewing Angle
- + Supports vertical and horizontal screen
- + 10 point projection capacitive touchscreen
- + Cover plate anti riot and anti fingerprint
- + Video interface: HDMI+VGA
- + Back VESA wall hanging hole
- + Support OS:Windows/Android/Linux
- + 2-years Warranty



Optional:

- No Touch
- Private Filter
- AG Coating
- Media play
- Video interface: Display Port
- ALL-IN-ONE(Android /Windows)



TDS2102D Digital signage touch Monitor Specification

Model	2102D
Color	Black/Silver
Diagonal	21.5"
Aspect Ratio	16:9
Active Area	476.64X268.11(mm)
Dimensions	527X323.6X45.2(mm)
Resolution	1920 X1080FHD@60Hz
Viewing Angle	Horizontal: 89° /89°; Vertical: 89° /89°
Number of Colors	16.7M
Brightness	LCD panel : 300nits; PCAP : 275 nits
Contrast Ratio	1000:1
Response Time	14ms
Touch Technology	PCAP (Projected Capacitive) - 10 Touch
Input method	Finger, Capacitance pen(Standard) Latex gloves touch (pre commissioning required)
Transmittance	≥90%
Surface hardness	7H(Mohs)
Touch Interface	USB 2.0
Video Interface	HDMI+VGA
Speakers	TwoX2W internal speakers
Input Voltage	AC:100-240 VAC, 50/60 Hz
Sealability	Touchscreen sealed to bezel
Drop test	1kg steel ball falls from 1.2m without breaking
Weight(Unpackage)	5.6KG
Shipping Dimensions	600X395X175(mm)
Operating Temperature	0°C-40°C
Storage Temperature	-20°C-60°C
Humidity	Operating: 20% to 70%; Storage: 10% to 80%
MTBF	30,000 Hours
Power Supply	12V3A
VESA Mounting	75X75(mm), 100X100(mm)
Warranty	2-Years
Agency Approvals	FCC; CE; ROHS
Support OS	Windows/Linux\Android
What's in the Box	1*USB cable,1*HDMI cable,1*DC cable

TDS2102D-PCAP

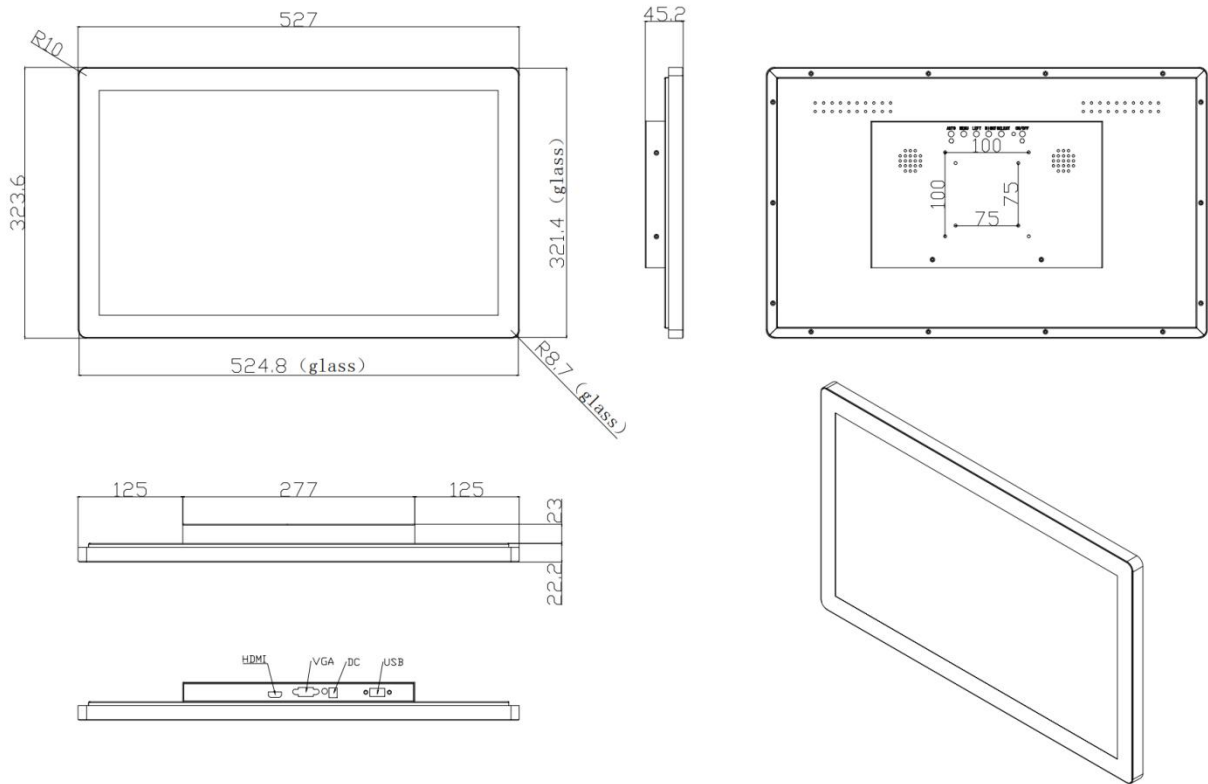

Dimensions are in millimeters

